



# ACM-A Series Metal Alloy Low-Resistance Resistor Product Specifications (Automotive Grade)

Document No.	IE-SP-080
Released Date	2019/10/25
Page No.	1

## 1 Scope:

- 1.1 This specification is applicable to lead free and halogen free of ROHS directive for ACM-A2512 Series metal alloy low-resistance resistor.
- 1.2 This product is for automotive electronic application.
- 1.3 AEC-Q200 qualified, grade 1.

## 2 Explanation Of Part Numbers

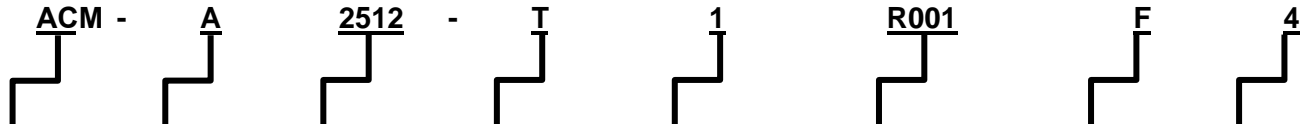

Type	Application	Size (inch)	Type of Packing	Rated Power	Resistance (4~6 Digits)	Tolerance	Packaging
LR: Metal Alloy Low Resistance Resistor	A: Automotive Grade	<ul style="list-style-type: none"> <li>1206</li> <li>2010</li> <li>2512</li> <li>2725</li> <li>2728</li> <li>4527</li> <li>4527S</li> </ul>	T: Taping	<ul style="list-style-type: none"> <li>C=0.5W</li> <li>1=1.0W</li> <li>A=1.5W</li> <li>2=2.0W</li> <li>3=3.0W</li> <li>B=3.5W</li> <li>4=4.0W</li> <li>5=5.0W</li> </ul>	EX: R001 = 1mΩ R010 = 10mΩ R100 = 100mΩ R00025 = 0.25mΩ	D=± 0.5% F=± 1.0% G=± 2.0% J=± 5.0%	A=500pcs 1=1,000pcs 2=2,000pcs 4=4,000pcs

<b>Written</b>	<b>IE</b>	<b>Checked</b>	<b>Approved</b>	<b>QA</b>	<b>Signing</b>	<b>Remark</b>	<b>Issue Dep. DATA Center.</b>
						IT'S NOT UNDER CONTROL FOR PDF FILE PLS NOTE THE VERSION STATED.. Do not copy without permission	Series No. <b>60</b>



**ACM-A Series Metal Alloy Low-Resistance Resistor Product Specifications (Automotive Grade)**

Document No.

IE-SP-080

Released Date

2019/10/25

Page No.

2

**3 Product Specifications:**

Type	# of Terminals	Max. Rating Power	Max. Rating Current	Max. Overload Current	T.C.R. (ppm/°C)	Resistance Range (mΩ)		Operating Temperature Range
						D (±0.5%)	F (±1%); G (±2%); J (±5%)	
1206	2	0.5W	31.62A	70.71A	0.5~0.9mΩ: ≤±175 1.0~15.0mΩ: ≤±75 15.1~50.0mΩ: ≤±50	7.0~50.0	0.5~50.0	-55~170°C
		1W	44.72A	100.00A	0.5~0.9mΩ: ≤±175 1.0~15.0mΩ: ≤±75 15.1~50.0mΩ: ≤±50	7.0~50.0	0.5~50.0	
		1.5W	54.77A	122.47A	0.5~0.9mΩ: ≤±175 1.0mΩ: ≤±75	--	0.5~1.0	
2010	2	1W	44.72A	100.00A	0.5~0.9mΩ: ≤±100 1.0~1.9mΩ: ≤±75 2.0~6.9mΩ: ≤±50 7.0~100mΩ: ≤±25	7.0~49	0.5~100	
		1.5W	54.77A	122.47A	0.5~0.9mΩ: ≤±100 1.0~1.9mΩ: ≤±75 2.0~6.9mΩ: ≤±50 7.0~40mΩ: ≤±25	7.0~40	0.5~40	
		2W	63.25A	141.42A	0.5~0.9mΩ: ≤±100 1.0~1.9mΩ: ≤±75 2.0~6.9mΩ: ≤±50 7.0~12mΩ: ≤±25	7.0~12	0.5~12	
2512	2	1W	57.74A	129.10A	0.3mΩ: ≤±150 0.5~1.0mΩ: ≤±75 1.1~3.0mΩ: ≤±50 3.1~100mΩ: ≤±25	7.0~50	0.3~100	
		1.5W	70.71A	158.11A				
		2W	81.65A	182.57A	0.3mΩ: ≤±150 0.5~1.0mΩ: ≤±75 1.1~3.0mΩ: ≤±50 3.1~75mΩ: ≤±25	7.0~50	0.3~75.0	
		3W	100.00A	223.61A	0.3mΩ: ≤±150 0.5~1.0mΩ: ≤±75 1.1~2.5mΩ: ≤±50 2.6~9.9mΩ: ≤±25	7.0~9.9	0.3~9.9	
2725	2	4W	126.49A	316.23A	0.20mΩ: ≤±100 0.25~3.0mΩ: ≤±50	--	0.20~3.0	
		5w	158.11A	353.55A	0.20 mΩ: ≤±100 0.25~0.5mΩ: ≤±50	--	0.20~0.5	
2728	2	3W	27.39A	61.24A	4.0~100mΩ: ≤±25	4.0~19.0	4.0~100	
		3.5W	29.58A	66.14A	4.0~100mΩ: ≤±25	4.0~19.0	4.0~100	
		4W	31.62A	70.71A	4.0~ 50.0mΩ: ≤±25	4.0~19.0	4.0~50.0	
4527S (without heat sink)	2	2W	63.25A	141.42A	0.5~1.0mΩ: ≤±75 1.1~200mΩ: ≤±50	7.0 ~100	0.5~200	
		3W	77.5A	173.21A	0.5~1.0mΩ: ≤±75 1.1~27mΩ: ≤±50	7.0 ~27	0.5~27	
		5W	100A	223.61A	0.5~1.0mΩ: ≤±75 1.1~7.5mΩ: ≤±50	7.0 ~7.5	0.5~7.5	

Remark

IT'S NOT UNDER CONTROL FOR PDF FILE  
PLS NOTE THE VERSION STATED..

Issue Dep. DATA Center.

Do not copy without permission

Series No. **60**



**ACM-A Series Metal Alloy Low-Resistance Resistor Product Specifications (Automotive Grade)**

Document No.	IE-SP-080
Released Date	2019/10/25
Page No.	3

Type	# of Terminals	Max. Rating Power	Max. Rating Current	Max. Overload Current	T.C.R. (ppm/°C)	Resistance Range (mΩ)		Operating Temperature Range
						D (±0.5%)	F (±1%); G (±2%); J (±5%)	
4527	2	5W	100A	223.61A	0.5~1.0mΩ: ≤±75 1.1~120mΩ: ≤±50	7.0 ~120	0.5~120	-55~170°C

3.1 Power Derating Curve: Operating Temperature Range : - 55 ~+170 °C  
 For resistors operated in ambient temperatures 70°C, power rating shall be derated in accordance with the curve below:

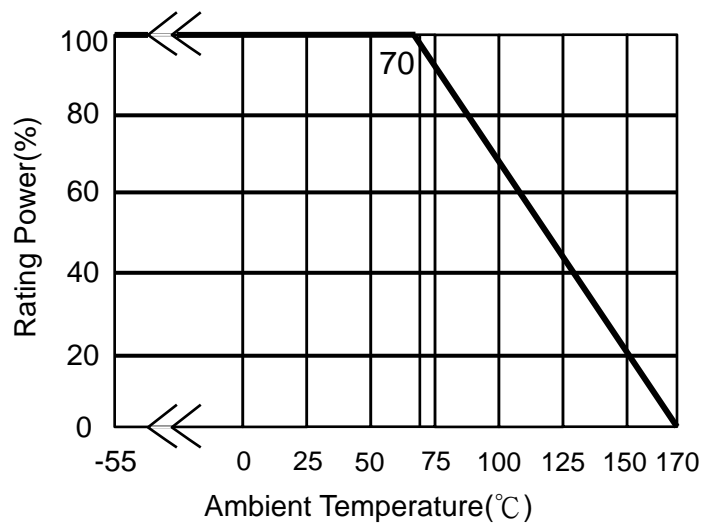

3.2 Rating Current:

The following equation may be used to determine the DC (Direct Current) or AC (Alternating Current) currents (RMS, root mean square value) of normal rated power. However, if the result value exceeds the highest current of regulated standards, the highest normal rated power is to be used.

Remark:

$$I = \sqrt{P/R}$$

I=Rating Current(A)  
 P= Rating Power(W)  
 R=Resistance(Ω)

Remark	IT'S NOT UNDER CONTROL FOR PDF FILE PLS NOTE THE VERSION STATED..	Issue Dep. <b>DATA Center.</b>
	Do not copy without permission	



**ACM-A Series Metal Alloy Low-Resistance Resistor Product Specifications (Automotive Grade)**

Document No.

IE-SP-080

Released Date

2019/10/25

Page No.

4

**4 Physical Dimensions:**

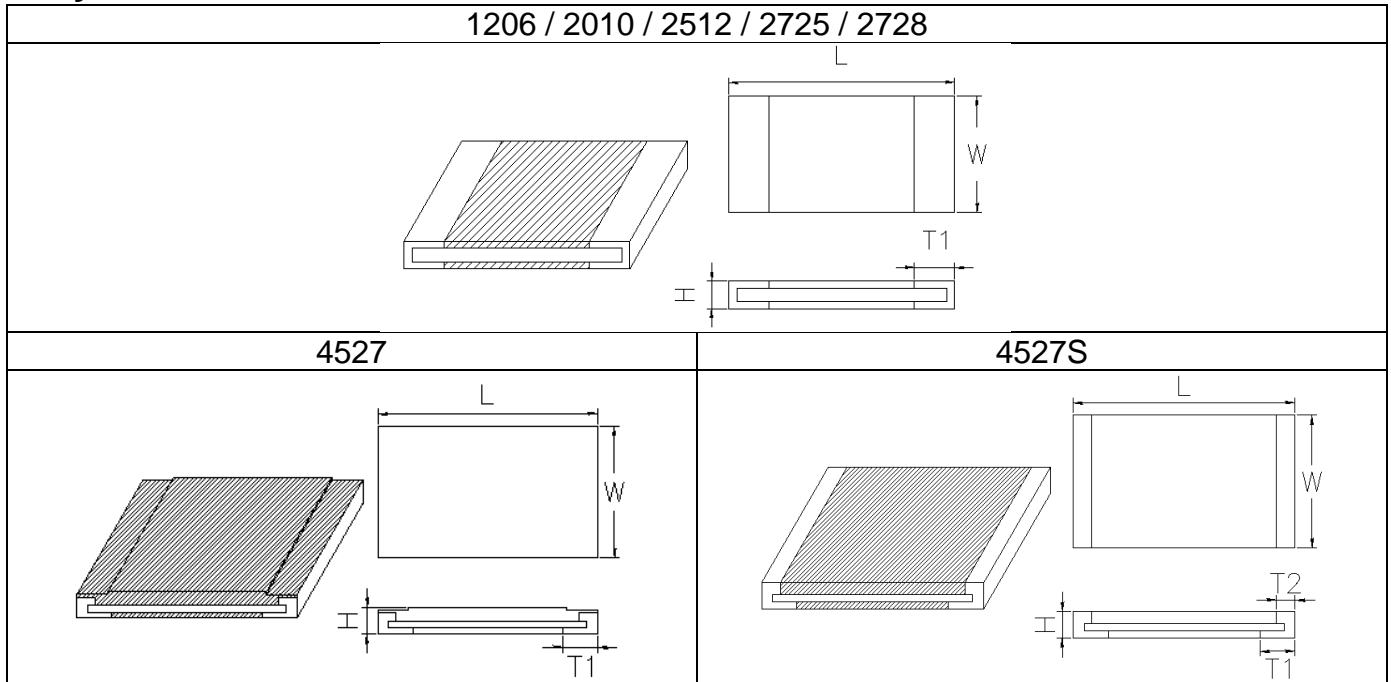

Type	Maximum Power Rating (Watts)	Resistance Range (mΩ)	Dimensions - in inches (millimeters)			
			L	W	H	T1
1206	0.5 & 1.0	0.5~0.6	0.126±0.010 (3.200±0.254)	0.063±0.010 (1.600±0.254)	0.039±0.010 (1.000±0.254)	0.029±0.010 (0.725±0.254)
		1.0			0.025±0.010 (0.645±0.254)	0.020±0.010 (0.508±0.254)
		2.0 ~ 4.0			0.022±0.010 (0.545±0.254)	0.024±0.010 (0.600±0.254)
		5.0			0.020±0.010 (0.508±0.254)	0.020±0.010 (0.508±0.254)
	1.5	6.0 ~50.0			0.039±0.010 (1.000±0.254)	0.029±0.010 (0.725±0.254)
		0.5~0.6			0.025±0.010 (0.645±0.254)	0.020±0.010 (0.508±0.254)
2010	1.0 1.5 2.0	0.5 ~ 0.9	0.200±0.010 (5.080±0.254)	0.100±0.010 (2.540±0.254)	0.031±0.010 (0.787±0.254)	0.057±0.010 (1.440±0.254)
		1.0 ~ 3.0				0.051±0.010 (1.295±0.254)
		3.1 ~ 4.0			0.025±0.010 (0.645±0.254)	0.031±0.010 (0.787±0.254)
		4.1 ~100.0				
2512	1.0 & 1.5	0.3	0.246±0.010 (6.248±0.254)	0.126±0.010 (3.202±0.254)	0.040±0.010 (1.000±0.254)	0.079±0.010 (2.02±0.254)
		0.5 ~ 0.7			0.031±0.010 (0.787±0.254)	0.079±0.010 (2.02±0.254)
		0.75				0.054±0.010 (1.374±0.254)
		0.8 ~ 3.0			0.031±0.010 (0.787±0.254)	0.074±0.010 (1.880±0.254)
		3.1 ~ 4.0				0.066±0.010 (1.676±0.254)
		4.1 ~78.0			0.025±0.010 (0.645±0.254)	0.044±0.010 (1.118±0.254)
		78.1~ 100.0			0.025±0.010 (0.645±0.254)	0.034±0.010 (0.868±0.254)

Remark	IT'S NOT UNDER CONTROL FOR PDF FILE PLS NOTE THE VERSION STATED..	Issue Dep. DATA Center.
	Do not copy without permission	Series No. <b>60</b>



**ACM-A Series Metal Alloy Low-Resistance Resistor Product Specifications (Automotive Grade)**

**Document No.**

**IE-SP-080**

**Released Date**

**2019/10/25**

**Page No.**

**5**

Type	Maximum Power Rating (Watts)	Resistance Range (mΩ)	Dimensions - in inches (millimeters)				
			L	W	H	T1	
2512	2.0	0.3	0.246±0.010 (6.248±0.254)	0.126±0.010 (3.202±0.254)	0.040±0.010 (1.000±0.254)	0.079±0.010 (2.02±0.254)	
		0.5~ 0.7			0.031±0.010 (0.787±0.254)	0.079±0.010 (2.02±0.254)	
		0.75				0.054±0.010 (1.374±0.254)	
		0.8 ~ 3.0				0.074±0.010 (1.880±0.254)	
		3.1 ~ 4.0				0.066±0.010 (1.676±0.254)	
		4.1 ~75.0				0.0254±0.010 (0.645±0.254)	0.044±0.010 (1.118±0.254)
	3.0	0.3~0.5				0.040±0.010 (1.000±0.254)	0.079±0.010 (2.02±0.254)
		0.7			0.031±0.010 (0.787±0.254)	0.074±0.010 (1.880±0.254)	
		0.75				0.054±0.010 (1.374±0.254)	
		0.8 ~ 2.9				0.044±0.010 (1.118±0.254)	
		3.0~3.5				0.074±0.010 (1.880±0.254)	
		3.6 ~ 4.0				0.066±0.010 (1.676±0.254)	
		4.1 ~ 9.9				0.025±0.010 (0.645±0.254)	0.044±0.010 (1.118±0.254)
		4.0&5.0				0.20~0.30	0.039±0.010 (0.991±0.254)
0.35 ~0.45	0.075±0.010 (1.904±0.254)						
0.60	0.071±0.010 (1.803±0.254)						
0.75	0.059±0.010 (1.504±0.254)						
1.0	0.043±0.010 (1.092±0.254)		0.085±0.010 (2.159±0.254)				
1.5	0.039±0.010 (0.991±0.254)		0.035±0.010 (0.889±0.254)				
2.0	0.071±0.010 (1.803±0.254)						
2.25~2.5	0.065±0.010 (1.651±0.254)						
3.0	0.051±0.010 (1.295±0.254)						
2728	3.0, 3.5 & 4.0	4.0~100.0	0.264±0.010 (6.706±0.254)	0.283±0.010 (7.188±0.254)	0.039±0.010 (0.991±0.254)	0.045±0.010 (1.143±0.254)	

**Remark**

IT'S NOT UNDER CONTROL FOR PDF FILE  
PLS NOTE THE VERSION STATED..

Issue Dep.**DATA Center.**

Do not copy without permission

Series No. **60**



**ACM-A Series Metal Alloy Low-Resistance Resistor Product Specifications (Automotive Grade)**

Document No.	IE-SP-080
Released Date	2019/10/25
Page No.	6

Type	Maximum Power Rating (Watts)	Resistance Range (mΩ)	Dimensions - in inches (millimeters)				
			L	W	H	T1	T2
4527S (without heat sink)	2.0	0.5	0.450±0.010 (11.430±0.254)	0.270±0.010 (6.850±0.254)	0.055±0.010 (1.400±0.254)	0.136±0.010 (3.465±0.254)	0.038±0.010 (0.965±0.254)
		0.6 ~ 3.0				0.127±0.010 (3.215±0.254)	
		4.0 ~ 5.0				0.071±0.010 (1.815±0.254)	
		5.1 ~ 100				0.136±0.010 (3.465±0.254)	
	3.0	0.5				0.127±0.010 (3.215±0.254)	
		0.6 ~ 3.0				0.071±0.010 (1.815±0.254)	
		4.0 ~ 5.0				0.136±0.010 (3.465±0.254)	
		5.1 ~ 27				0.127±0.010 (3.215±0.254)	
	5.0	0.5				0.071±0.010 (1.815±0.254)	
		0.6 ~ 3.0				0.143±0.010 (3.645±0.254)	
		4.0 ~ 5.0				0.127±0.010 (3.215±0.254)	
		5.1 ~ 7.5				0.071±0.010 (1.815±0.254)	
4527	5.0	0.5	0.450±0.010 (11.430±0.254)	0.270±0.010 (6.850±0.254)	0.059±0.010 (1.500±0.254)	0.143±0.010 (3.645±0.254)	X
		0.6 ~ 3.0				0.127±0.010 (3.215±0.254)	
		4.0 ~ 5.0				0.071±0.010 (1.815±0.254)	
		5.1 ~ 120					

**4.1 Material of Alloy**

Type	Watts	Material	Resistance
1206	0.5	Copper-Manganese Alloy	≤ 4.0mΩ
	1.0	Iron-Chromium Aluminium Alloy	> 4.0mΩ
	1.5		
2010	1.0	Copper-Manganese Alloy	≤ 4.0mΩ
	1.5	Iron-Chromium Aluminium Alloy	> 4.0mΩ
	2.0		
2512	1.0	Copper-Manganese Alloy	< 3.5mΩ
	1.5	Iron-Chromium Aluminium Alloy	≥ 3.5mΩ
	2.0		
	3.0	Copper-Manganese Alloy	≤ 2.5mΩ
		Iron-Chromium Aluminium Alloy	≥ 3.0mΩ
2725	4.0	Copper-Manganese Alloy	≤ 0.5mΩ
	5.0	Iron-Chromium Aluminium Alloy	> 0.5mΩ
2728	3.0	Iron-Chromium Aluminium Alloy	All
	3.5		
	4.0		
4527	2.0	Copper-Manganese Alloy	≤ 3.0mΩ
	3.0	Iron-Chromium Aluminium Alloy	≥ 4.0mΩ
	5.0		

Remark	IT'S NOT UNDER CONTROL FOR PDF FILE PLS NOTE THE VERSION STATED..	Issue Dep. DATA Center.
	Do not copy without permission	Series No. <b>60</b>



**ACM-A Series Metal Alloy Low-Resistance Resistor Product Specifications (Automotive Grade)**

Document No.	IE-SP-080
Released Date	2019/10/25
Page No.	7

**5 Reliability Performance:**

**5.1 Electrical Performance:**

Test Item	Conditions of Test	Test Limits																																	
Temperature Coefficient of Resistance (TCR)	<ul style="list-style-type: none"> <li>TCR (ppm/°C) = <math>\frac{(R2-R1)}{R1 (T2-T1)} \times 10^6</math></li> <li>R1: resistance of room temperature</li> <li>R2: resistance of 150 °C</li> <li>T1: Room temperature</li> <li>T2: Temperature at 150 °C</li> <li>Refer to JIS C 5201-1 4.8</li> </ul>	Refer to Paragraph 3. general specifications																																	
Short Time Overload	<p>Applied Overload for 5 seconds and release the load for about 30 minutes, then measure its resistance variance rate. (Overload condition refer to below):</p> <table border="1"> <thead> <tr> <th>Type</th> <th>Power (W)</th> <th># of rated power</th> </tr> </thead> <tbody> <tr> <td rowspan="3">1206</td> <td>0.5</td> <td rowspan="3">5 times</td> </tr> <tr> <td>1.0</td> </tr> <tr> <td>1.5</td> </tr> <tr> <td>2010</td> <td>1.0</td> <td rowspan="3">5 times</td> </tr> <tr> <td rowspan="3">2512</td> <td>1.0</td> </tr> <tr> <td>1.5</td> </tr> <tr> <td>2.0</td> </tr> <tr> <td rowspan="2">2725</td> <td>4.0</td> <td>5 times</td> </tr> <tr> <td>5.0</td> <td>5 times</td> </tr> <tr> <td rowspan="3">2728</td> <td>3.0</td> <td rowspan="3">5 times</td> </tr> <tr> <td>3.5</td> </tr> <tr> <td>4.0</td> </tr> <tr> <td rowspan="3">452S</td> <td>2.0</td> <td rowspan="3">5 times</td> </tr> <tr> <td>3.0</td> </tr> <tr> <td>5.0</td> </tr> <tr> <td>4527</td> <td>5.0</td> <td></td> </tr> </tbody> </table> <p>Refer to JIS C 5201-1 4.13</p>	Type	Power (W)	# of rated power	1206	0.5	5 times	1.0	1.5	2010	1.0	5 times	2512	1.0	1.5	2.0	2725	4.0	5 times	5.0	5 times	2728	3.0	5 times	3.5	4.0	452S	2.0	5 times	3.0	5.0	4527	5.0		$\leq \pm 0.5\%$ $\leq \pm 2.0\%$ ( 4527 & 4527S series)
Type	Power (W)	# of rated power																																	
1206	0.5	5 times																																	
	1.0																																		
	1.5																																		
2010	1.0	5 times																																	
2512	1.0																																		
	1.5																																		
	2.0																																		
2725	4.0	5 times																																	
	5.0	5 times																																	
2728	3.0	5 times																																	
	3.5																																		
	4.0																																		
452S	2.0	5 times																																	
	3.0																																		
	5.0																																		
4527	5.0																																		
Insulation Resistance	<p>Put the resistor in the fixture, add 100 VDC in + , - terminal for 60secs then measured the insulation resistance between electrodes and insulating enclosure or between electrodes and base material.</p> <p>Refer to JIS-C5201-1 4.6</p>	$\geq 10^9 \Omega$																																	
Dielectric Withstanding Voltage	<p>Applied 500VAC for 1 minute, and Limit surge current 50 mA (max.)</p> <p>Refer to JIS-C5201-1 4.7</p>	No short or burned on the appearance.																																	

Remark	<div style="border: 1px solid black; padding: 5px; display: inline-block;">           IT'S NOT UNDER CONTROL FOR PDF FILE            PLS NOTE THE VERSION STATED..         </div>	Issue Dep. <b>DATA Center.</b>
	Do not copy without permission	

**5.2 Mechanical /Constructional Performance:**

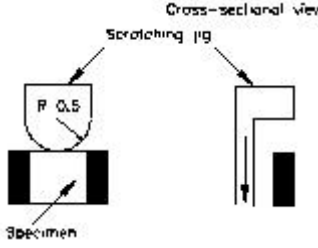
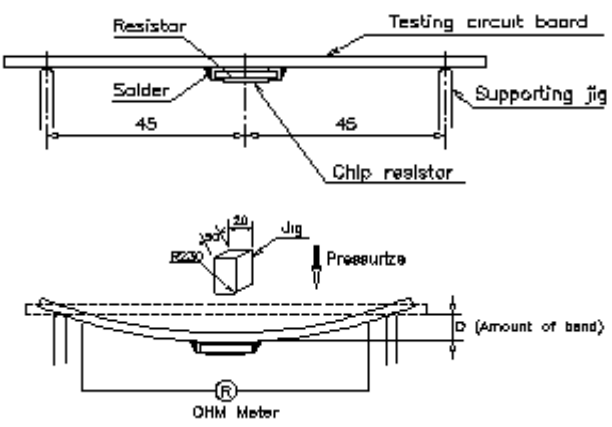
Test Item	Conditions of Test	Test Limits
Resistance to Solder Heat	The tested resistor be immersed 25 mm/sec into molten solder of 260±5°C for 10±1secs. Then the resistor is left in the room for 1 hour, and measured its resistance variance rate. Refer to JIS-C5201-1 4.18	≤ ±0.5% No evidence of mechanical damage
Solderability	Add flux into tested resistors, immersion into solder bath in temperature 245±5°C for 3±0.5secs. Refer to JIS-C5201-1 4.17	Solder coverage over 95%
Core Body Strength	Applied R0.5 test probe at its central part then pushing 5N force on the sample for 10 sec. Refer to JIS-C5201-1 4.15	≤ ±0.5% No evidence of mechanical damage
Joint Strength of Solder	<p>Preconditioning Put tested resistor in the apparatus of PCT, at a temperature of 105°C, humidity of 100% RH, and pressure of 1.22×10<sup>5</sup> Pa for a duration of 4 hours. Then after left the specimen in a temperature for 2 hours or more. Test method:</p> <p>◎Test item 1 (Adhesion): A static load using a R0.5 scratch tool shall be applied on the core of the component and in the direction of the arrow and held for 10 seconds and under load measured its resistance variance rate. Load:17.7N</p>  <p>Refer to JIS-C5201-1 4.32</p>	<p>Test item 1: (1). ≤ ±0.5% (2).No evidence of mechanical damage. No terminal peeling off.</p> <p>Test item 2: (1). ≤ ±0.5% (2).No evidence of mechanical damage. No terminal peeling off and core body cracked.</p>
	<p>◎Test item 2 (Bending Strength): Solder tested resistor on to PC board add force in the middle down, and under load measured its resistance variance rate. D:2mm</p>  <p>Refer to JIS-C5201-1 4.33</p>	

Remark

IT'S NOT UNDER CONTROL FOR PDF FILE  
PLS NOTE THE VERSION STATED..

Do not copy without permission

Issue Dep. DATA Center.

Series No. **60**





**ACM-A Series Metal Alloy Low-Resistance Resistor Product Specifications (Automotive Grade)**

Document No.	IE-SP-080
Released Date	2019/10/25
Page No.	9

Test Item	Conditions of Test	Test Limits
Resistance to solvent	The tested resistor be immersed into isopropyl alcohol of 20~25°C for 60secs, then the resistor is left in the room for 48 hrs. Refer to JIS-C5201-1 4.29	≤ ±0.5% No evidence of mechanical damage
Vibration	The resistor shall be mounted by its terminal leads to the supporting terminals on the solid table. The entire frequency range :from 10 Hz to 55 Hz and return to 10 Hz, shall be transferred in 1 min. Amplitude : 1.5mm This motion shall be applied for a period of 4 hours in each 3 mutually perpendicular directions (a total of 12hrs) Refer to JIS-C5201-1 4.22	≤ ±0.5% No evidence of mechanical damage

**5.3 Environmental Performance:**

Test Item	Conditions of Test	Test Limits								
Low Temperature Exposure (Storage)	Put the tested resistor in chamber under temperature -55±2°C for 1,000 hours. Then leaving the tested resistor in room temperature for 60 minutes, and measure its resistance variance rate. Refer to JIS-C5201-1 4.23.4	≤ ±0.5% No evidence of mechanical damage								
High Temperature Exposure (Storage)	Put tested resistor in chamber under temperature 170±5°C for 1,000 hours. Then leaving the tested resistor in room temperature for 60 minutes , and measure its resistance variance rate. Refer to JIS-C5201-1 4.23.2	≤ ±1.0% No evidence of mechanical damage								
Temperature Cycling (Rapid Temperature Change)	Put the tested resistor in the chamber under the temperature cycling which shown in the following table shall be repeated 1,000 times consecutively. Then leaving the tested resistor in the room temperature for 60 minutes, and measure its resistance variance rate. <table border="1" style="margin-left: 20px;"> <thead> <tr> <th></th> <th>Testing Condition</th> </tr> </thead> <tbody> <tr> <td>Lowest Temperature</td> <td>-55 +0/-10°C</td> </tr> <tr> <td>Highest Temperature</td> <td>150 +10/-0°C</td> </tr> <tr> <td>Dwell time</td> <td>30min maximum</td> </tr> </tbody> </table> Refer to JESD22-A104		Testing Condition	Lowest Temperature	-55 +0/-10°C	Highest Temperature	150 +10/-0°C	Dwell time	30min maximum	≤ ±0.5% No evidence of mechanical damage
	Testing Condition									
Lowest Temperature	-55 +0/-10°C									
Highest Temperature	150 +10/-0°C									
Dwell time	30min maximum									
Moisture Resistance (Climatic Sequence)	Put the tested resistor in chamber and subject to 10 cycles of damp heat and without power. Each one of which consists of the steps 1 to 7 (Figure 1). Then leaving the tested resistor in room temperature for 24 hr, and measure its resistance variance rate. Refer to MIL-STD 202 Method 106	≤ ±0.5% No evidence of mechanical damage								
Bias Humidity	Put the tested resistor in chamber under 85± 5°C and 85± 5%RH with 10% bias and load the rated current for 90 minutes on, 30 minutes off, total 1,000 hours. Then leaving the tested resistor in room temperature for 60 minutes, and measure its resistance variance rate. Refer to JIS-C5201-1 4.24	≤ ±0.5% No evidence of mechanical damage								

<b>Remark</b>	<div style="border: 1px solid black; padding: 5px; display: inline-block;">           IT'S NOT UNDER CONTROL FOR PDF FILE            PLS NOTE THE VERSION STATED..         </div>	Issue Dep. <b>DATA Center.</b>
	Do not copy without permission	Series No. <b>60</b>



# ACM-A Series Metal Alloy Low-Resistance Resistor Product Specifications (Automotive Grade)

Document No.	IE-SP-080
Released Date	2019/10/25
Page No.	10

Test Item	Conditions of Test	Test Limits										
Whisker Test	◎Test item (Thermal Shock test): <table border="1"> <thead> <tr> <th colspan="2">Testing Condition</th> </tr> </thead> <tbody> <tr> <td>Minimum storage temperature</td> <td>-55+0/-10°C</td> </tr> <tr> <td>Maximum storage temperature</td> <td>85+10/-0°C</td> </tr> <tr> <td>Temperature-retaining time</td> <td>10 min.</td> </tr> <tr> <td>Number of temperature cycles</td> <td>1,500</td> </tr> </tbody> </table>	Testing Condition		Minimum storage temperature	-55+0/-10°C	Maximum storage temperature	85+10/-0°C	Temperature-retaining time	10 min.	Number of temperature cycles	1,500	Max. 50 μm
	Testing Condition											
Minimum storage temperature	-55+0/-10°C											
Maximum storage temperature	85+10/-0°C											
Temperature-retaining time	10 min.											
Number of temperature cycles	1,500											
◎Inspection: Inspect for whisker formation on specimens that underwent the acceleration test specified in subclause 4.2, with a magnifier (stereo microscope) of about 40 or higher magnification. If judgment is hard in this method, use a scanning electron microscope (SEM) of about 1,000 or higher magnification. By JESD Standard NO.22A121 class 2.												

## 5.4 Operational Life Endurance:

Test Item	Conditions of Test	Test Limits
Load Life	Put the tested resistor in chamber under temperature 70± 2°C and load the rated current for 90 minutes on 30 minutes off, total 1000 hours. Then leaving the tested resistor in room temperature for 60 minutes, and measure its resistance variance rate. Refer to JIS-C5201-1 4.25	≤ ±1.0% ≤ ±2.0% (4527 & 4527Sseries)
		No evidence of mechanical damage

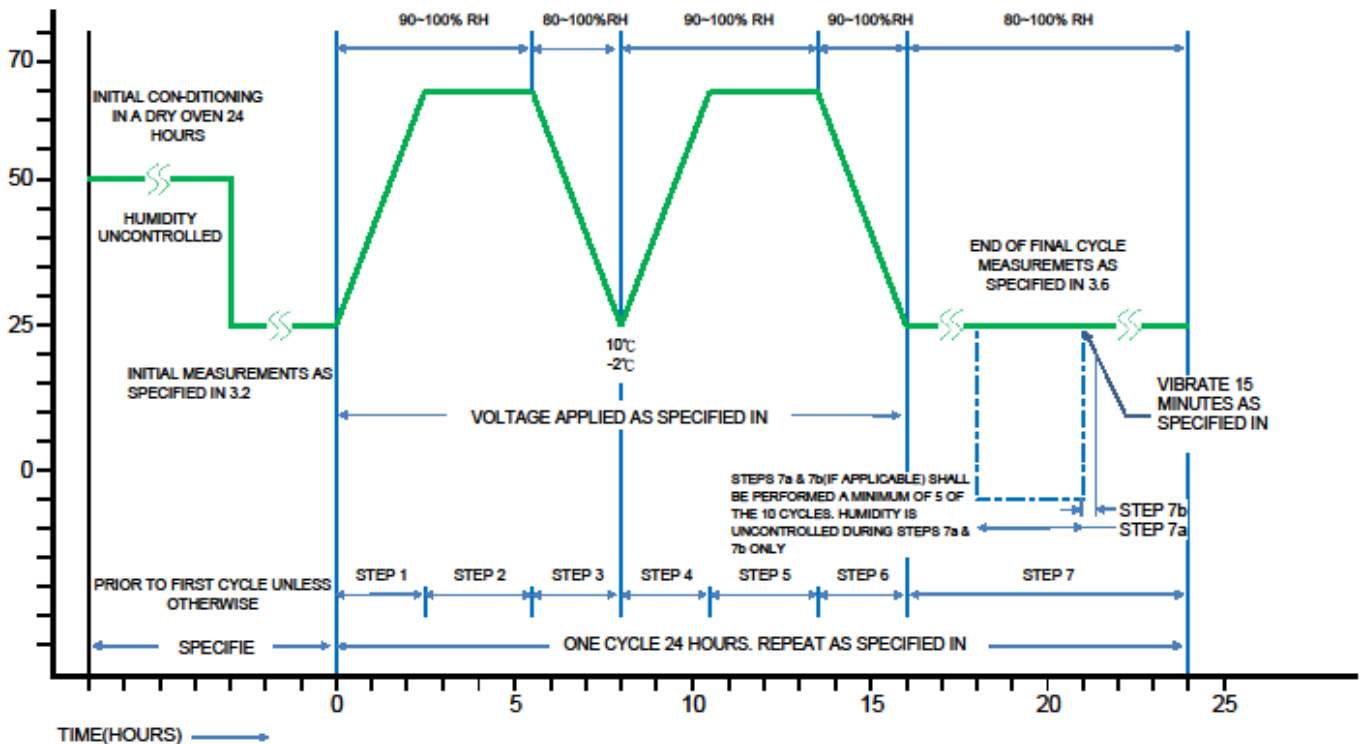

Remark	IT'S NOT UNDER CONTROL FOR PDF FILE PLS NOTE THE VERSION STATED..	Issue Dep. DATA Center.
	Do not copy without permission	Series No. <b>60</b>

## 6 Marking Format:

6.1 Product resistance is indicated by using two marking notation styles:

- a. "R" designates the decimal location in ohms, e.g.
  - For 5mΩ the product marking is R005;
  - For 25mΩ the product marking is R025;
  - For 100mΩ the product marking is R100.
- b. "m" designates the decimal location in milliohms, e.g.
  - For 5.5mΩ the product marking is 5m50;
  - For 25.5mΩ the product marking is 25m5.

6.2 1206 Series:(4-digits marking)

6.2.1 Above 1.0mΩ :

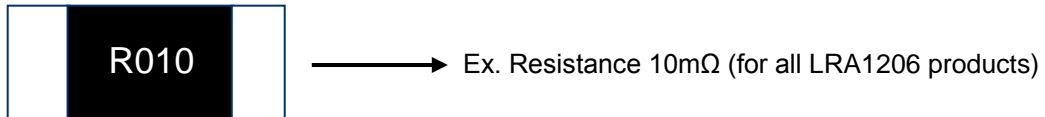

6.2.2 0.5~0.6 mΩ:(Square marking)

Recognize Top/Bottom side.

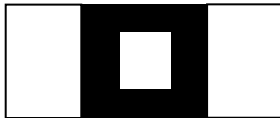

6.3 2010 Series:(4-digits marking)

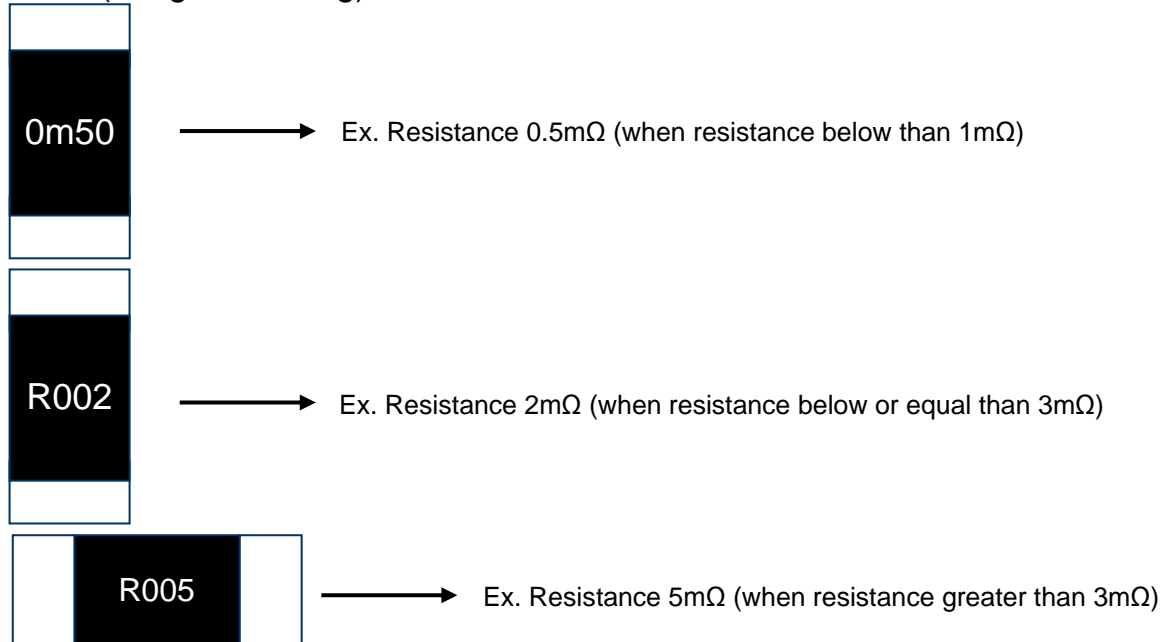

Remark

IT'S NOT UNDER CONTROL FOR PDF FILE  
PLS NOTE THE VERSION STATED..

Issue Dep. DATA Center.

Do not copy without permission

Series No. **60**



**ACM-A Series Metal Alloy Low-Resistance Resistor Product Specifications (Automotive Grade)**

Document No.	IE-SP-080
Released Date	2019/10/25
Page No.	12

6.4 2512 Series: (3-digits marking / 4-digits marking)

6.4.1  $\leq 4.0\text{m}\Omega$  (3-digits marking)

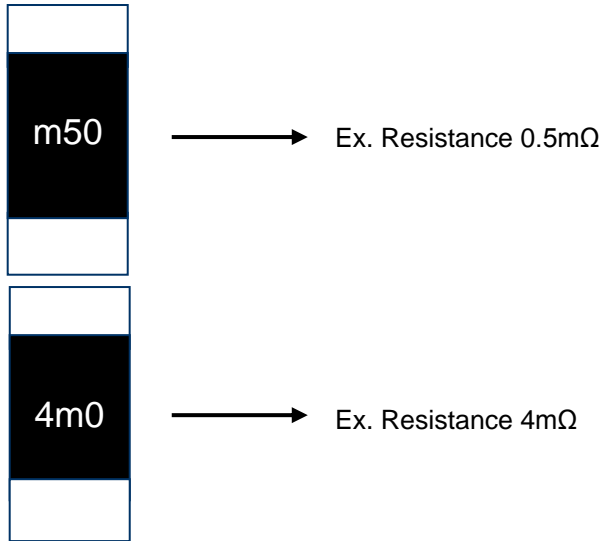

6.4.2  $> 4.0\text{m}\Omega$  (4-digits marking)

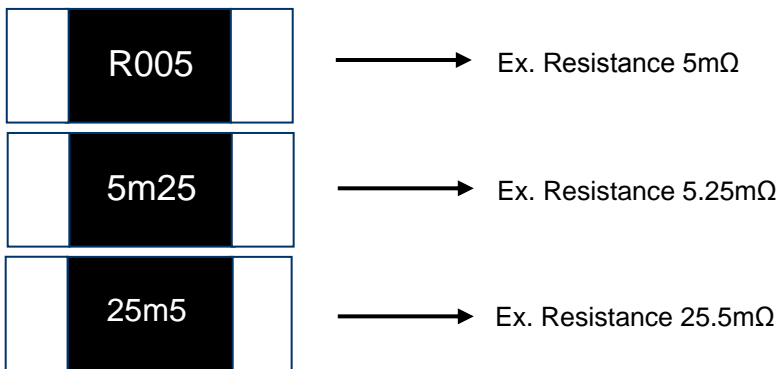

6.5 2725 Series: (4-digits marking)

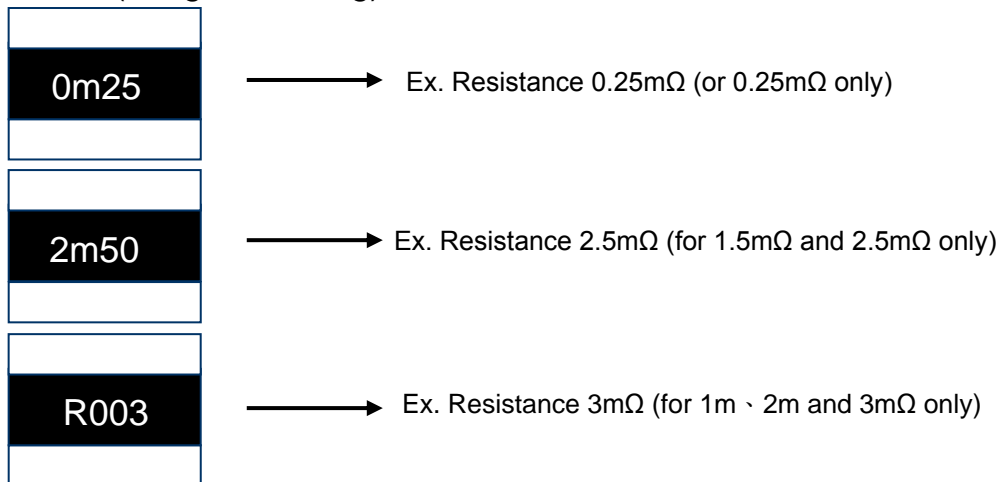

Remark	IT'S NOT UNDER CONTROL FOR PDF FILE PLS NOTE THE VERSION STATED..	Issue Dep. <b>DATA Center.</b>
	Do not copy without permission	Series No. <b>60</b>



**ACM-A Series Metal Alloy Low-Resistance Resistor Product Specifications (Automotive Grade)**

Document No.	IE-SP-080
Released Date	2019/10/25
Page No.	13

6.6 2728 Series: (4-digits marking)

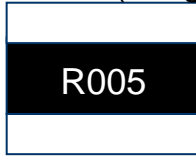

→ Ex. Resistance 5mΩ (for all LRA2728 products)

6.7 4527 Series: (4-digits marking)



→ Ex: Resistance 2mΩ.

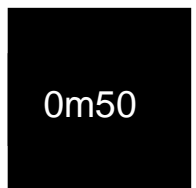

→ Ex: Resistance 0.5mΩ.

6.8 4527S Series: (4-digits marking)

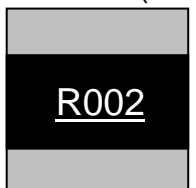

→ Ex: Resistance 2mΩ.

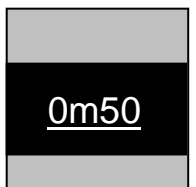

→ Ex: Resistance 0.5mΩ.

6.9 Marking Style:

Type	Marking	R	m	1	2	3	4	5	6	7	8	9	0
1206													
2010													
2512													
2725													
2728													
4527													
4527S													

7 Plating Thickness:

- 7.1 Ni ≥ 2μm
- 7.2 Sn(Tin) ≥ 3μm
- 7.3 Sn(Tin): Matte Sn

Remark	<div style="border: 1px solid black; padding: 5px; display: inline-block;">             IT'S NOT UNDER CONTROL FOR PDF FILE              PLS NOTE THE VERSION STATED..           </div>	Issue Dep. DATA Center.
	Do not copy without permission	



**ACM-A Series Metal Alloy Low-Resistance Resistor Product Specifications (Automotive Grade)**

Document No.	IE-SP-080
Released Date	2019/10/25
Page No.	14

**8 Measure Point:**

Bottom Side	型別	A	B
	1206	2.95±0.25	1.00±0.25
	2010	4.35±0.25	1.60±0.25
	2512	5.25±0.25	2.25±0.25
	2725	5.10±0.05	5.10±0.05
	2728	5.60±0.05	5.60±0.05
	4527	4.50±0.05	9.00±0.05
	單位 : mm		

**9 Taping specifications:**

9.1 Tape Dimensions:

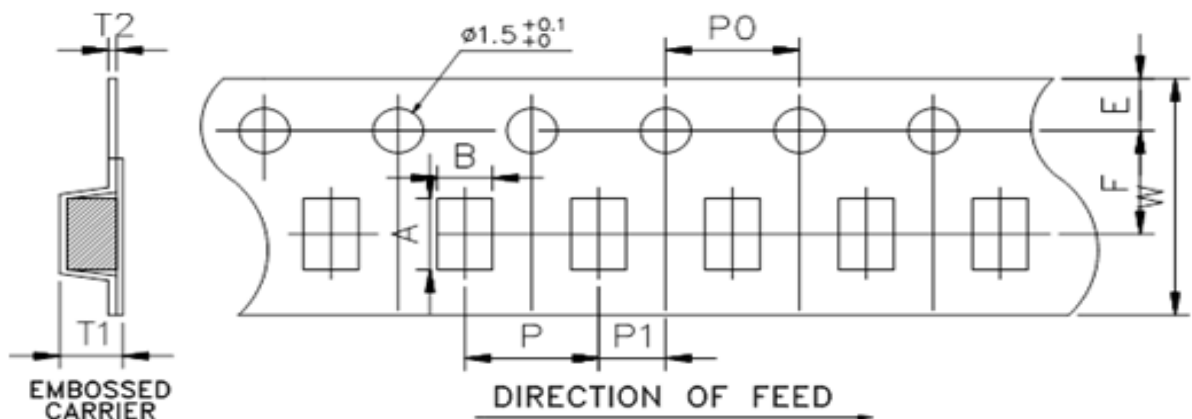

Unit: mm

DIM	A	B	W	E	F	T1	T2	P	P0	10*P0	P1
1206 (0.5~0.6mΩ)	3.50±0.10	1.90±0.10	8.0±0.15	1.75±0.10	3.5±0.10	1.27±0.10	0.23±0.10	4.0±0.10	4.0±0.10	40.0±0.20	2.0±0.10
1206 (≥1.0mΩ)	3.48±0.10	1.83±0.10	8.0±0.15	1.75±0.10	3.5±0.10	1.10±0.10	0.20±0.05	4.0±0.10	4.0±0.10	40.0±0.20	2.0±0.10
2010	5.45±0.10	2.90±0.10	12.0±0.15	1.75±0.10	5.5±0.10	1.33±0.10	0.23±0.05	4.0±0.10	4.0±0.10	40.0±0.20	2.0±0.10
2512 (0.3mΩ)	6.74±0.10	3.50±0.10	12.0±0.15	1.75±0.10	5.5±0.10	1.60±0.10	0.24±0.05	8.0±0.10	4.0±0.10	40.0±0.20	2.0±0.10
2512	6.75±0.10	3.50±0.10	12.0±0.15	1.75±0.10	5.5±0.10	1.30±0.10	0.20±0.05	4.0±0.10	4.0±0.10	40.0±0.20	2.0±0.10
2725	7.15±0.10	6.75±0.10	12.0±0.15	1.75±0.10	5.5±0.10	1.95±0.10	0.25±0.05	8.0±0.10	4.0±0.10	40.0±0.20	2.0±0.10
2728	7.15±0.10	7.70±0.10	12.0±0.15	1.75±0.10	5.5±0.10	1.45±0.10	0.25±0.05	12.0±0.10	4.0±0.10	40.0±0.20	2.0±0.10
4527	11.80±0.10	7.20±0.10	24.0±0.15	1.75±0.10	11.5±0.10	2.00±0.10	0.30±0.10	12.0±0.10	4.0±0.10	40.0±0.20	2.0±0.10
4527S	11.80±0.10	7.20±0.10	24.0±0.15	1.75±0.10	11.5±0.10	2.00±0.10	0.30±0.10	12.0±0.10	4.0±0.10	40.0±0.20	2.0±0.10

Remark

IT'S NOT UNDER CONTROL FOR PDF FILE  
PLS NOTE THE VERSION STATED..

Issue Dep. DATA Center.

Do not copy without permission

Series No. **60**



# ACMA Series Metal Alloy Low-Resistance Resistor Product Specifications (Automotive Grade)

Document No.	IE-SP-080
Released Date	2019/10/25
Page No.	15

## 9.2 Packaging model:

Type	Tape width	Max. Packaging Quantity (pcs/reel)		
		Embossed Plastic Type		
		4mm pitch	8mm pitch	12mm pitch
1206(0.5~0.6mΩ)	8mm	2,000pcs	--	--
1206(≥1.0mΩ)		4,000pcs		
2010	12mm	2,000pcs/4,000pcs	--	--
2512(0.3mΩ)		--	1,000pcs	--
2512		4,000pcs	--	--
2725		--	1,000pcs	--
2728		--	--	1,000pcs
4527 4527S	24mm	--	--	500pcs

## 9.3 Reel Dimensions:

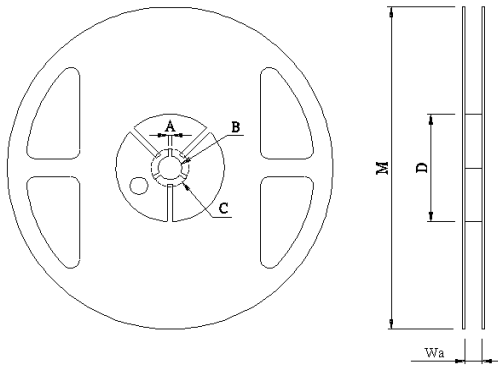

Unit: mm

Reel Type / Tape	W	M	A	B	C	D
7" reel for 8 mm tape	9.0 ± 0.5	178 ± 2.0	2.0 ± 0.5	13.5 ± 0.5	21.0 ± 0.5	60.0 ± 1.0
7" reel for 12 mm tape	13.8 ± 0.5					80.0 ± 1.0
7" reel for 24 mm tape	25.0 ± 1.0					60.0 ± 1.0

## 9.4 Label

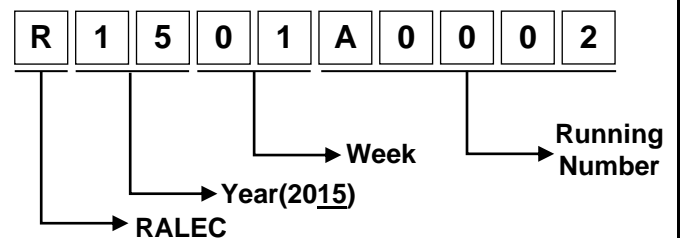
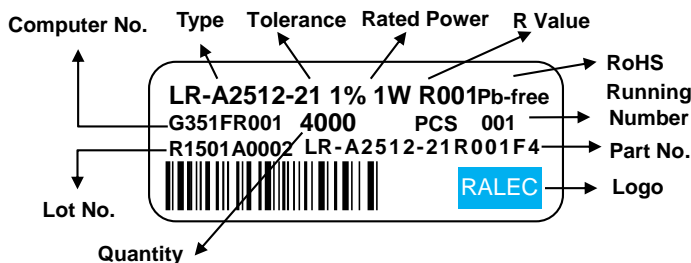

Remark	IT'S NOT UNDER CONTROL FOR PDF FILE PLS NOTE THE VERSION STATED..	Issue Dep. DATA Center.
	Do not copy without permission	
		Series No. <b>60</b>



**ACM-A Series Metal Alloy Low-Resistance Resistor Product Specifications (Automotive Grade)**

Document No.	IE-SP-080
Released Date	2019/10/25
Page No.	16

**9.5 Inner Box:**

Reel Number (for 8 mm tape)	Reel Number (for 12 mm tape)	Reel Number (for 24 mm tape)	D Dimension (mm)
1	-	-	12
2	1	-	24
3	2	1	36
4	-	-	48
5	3	2	60
6	4	-	72
7	-	3	84
8	-	-	96
9	-	-	108
10	-	4	120

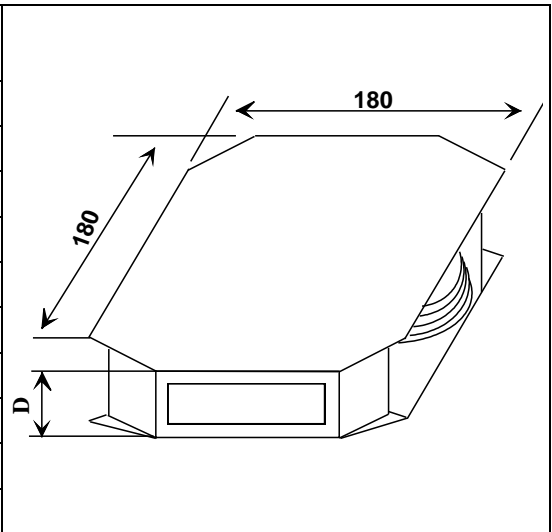

**9.6 Box:**

10R Inner Box Number	L(mm)	W(mm)	D(mm)
2	272	205	210
4	375	280	210
8	544	380	210

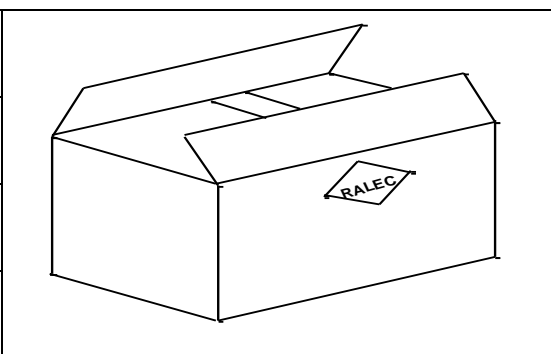

**9.7 Box(For China):**

10R Inner Box Number	L(mm)	W(mm)	D(mm)
2	272	205	210
4	375	280	210
8	544	380	210

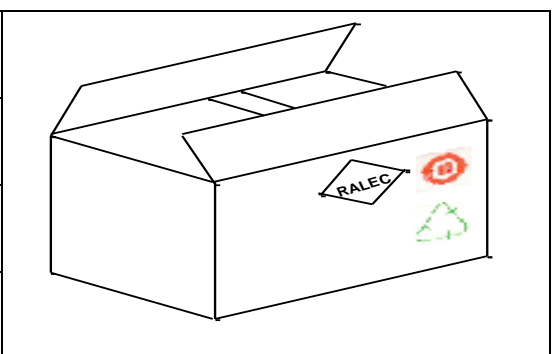

Remark	<div style="border: 1px solid black; padding: 5px; display: inline-block;">                 IT'S NOT UNDER CONTROL FOR PDF FILE                  PLS NOTE THE VERSION STATED..             </div>	Issue Dep. <b>DATA Center.</b>
	Do not copy without permission	Series No. <b>60</b>





**10 Technical application notes:(This for recommendation, please customer perform adjustment according to actual application)**

**10.1 Recommend Soldering Method:**

10.1.1 Surface-mount components are tested for solderability at a temperature of 245 °C for 3 seconds.

10.1.2 Typical examples of soldering processes that provide reliable joints without any damage are given in below:

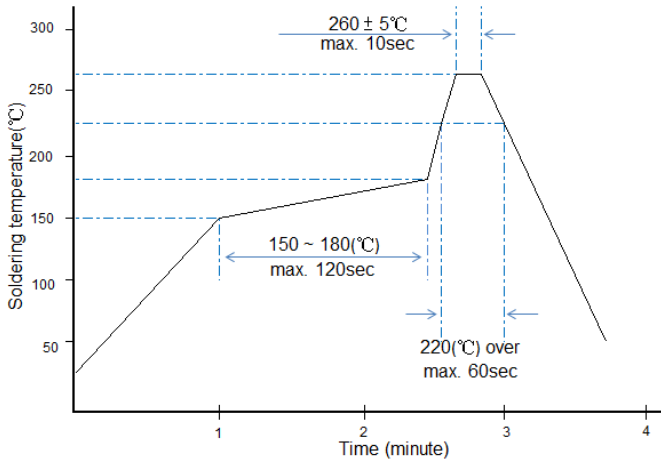

Recommended IR Reflow Soldering Profile  
MEET J-STD-020D

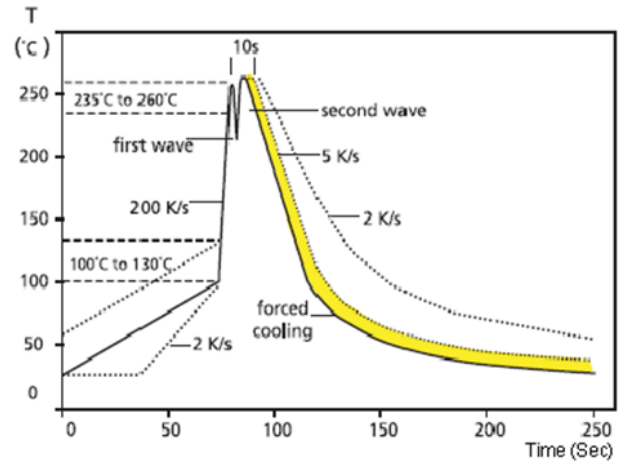

Recommended double-wave Soldering Profile  
Typical values (solid line)  
Process limits (dotted line)

10.1.3 Soldering Iron: temperature 350°C ± 10°C , dwell time shall be less than 3 sec.

Remark

IT'S NOT UNDER CONTROL FOR PDF FILE  
PLS NOTE THE VERSION STATED..

Issue Dep. DATA Center.

Do not copy without permission

Series No. **60**



**ACM-A Series Metal Alloy Low-Resistance Resistor Product Specifications (Automotive Grade)**

Document No.	IE-SP-080
Released Date	2019/10/25
Page No.	18

10.2 Recommend Land Pattern:

When a component is soldered, the resistance after soldering changes slightly depending on the size of the soldering area and the amount of soldering. When designing a circuit, it is necessary to consider the effect of a decrease or increase in its resistance.

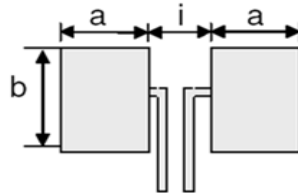

Type	Maximum Power Rating (Watts)	Resistance Range (mΩ)	Dimensions - in millimeters			
			a	b	i	
1206	0.5 & 1.0 & 1.5	0.5~0.6	1.65	2.18	0.90	
		1.0 ~ 50.0	1.60		1.00	
2010	1.0	0.5 ~ 3.0	2.89	2.92	1.22	
		3.1 ~ 100.0	2.29		2.41	
2512	1.0 & 1.5	0.3 ~ 0.7	3.05	3.68	1.27	
		0.8~4.0			2.19	3.00
		0.75				3.18
	2.0	4.1 ~ 100.0	2.11		1.27	
		0.3 ~ 0.7	3.05		3.00	
		0.8~4.0			2.19	3.18
	0.75	1.27				
	3.0	4.1 ~ 75.0	2.11		3.00	
		0.3~0.5	3.05		1.80	
0.6~2.9 & 4.1 ~ 9.9		3.00				
3.0 ~ 4.0	2.79	1.27				
2725	4.0&5.0	0.20 ~ 3.0	3.18	6.86	1.32	
2728	3.0 & 3.5 & 4.0	4.0 ~ 100.0	2.75	7.82	3.51	
4527S	2.0	0.5 ~ 5.0	5.80	8.74	3.51	
		5.1 ~ 100.0	4.15		6.81	
	3.0	0.5 ~ 5.0	5.80		3.51	
		5.1 ~ 27.0	4.15		6.81	
	5.0	0.5 ~ 5.0	5.80		3.51	
		5.1 ~ 7.5	4.15		6.81	
4527	5.0	0.5 ~ 5.0	5.80	8.74	3.51	
		5.1 ~ 200.0	4.15		6.81	

Remark	<div style="border: 1px solid black; padding: 5px; display: inline-block;">           IT'S NOT UNDER CONTROL FOR PDF FILE            PLS NOTE THE VERSION STATED..         </div>	Issue Dep. <b>DATA Center.</b>
	Do not copy without permission	



**ACM-A Series Metal Alloy Low-Resistance Resistor Product Specifications (Automotive Grade)**

Document No.	IE-SP-080
Released Date	2019/10/25
Page No.	19

10.3 Recommend dispensing method

10.3.1 The structure of RALEC metal alloy resistor that both side of main body would be thinner due to process factor (as the photo below).

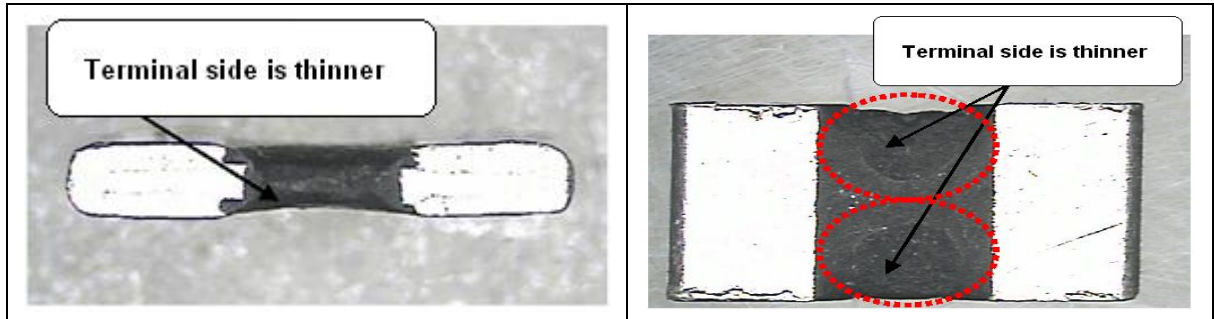

10.3.2 When customer performs wave solder process shall take note on the dispensing gap. If the gap between two dispensing is over, the red-glue will not adhesive the resistor body and be dropped out (as photo 1). Therefore, we suggest customer to narrow down the dispenser gap (as photo 2), or dispenser on the body center (as photo 3)

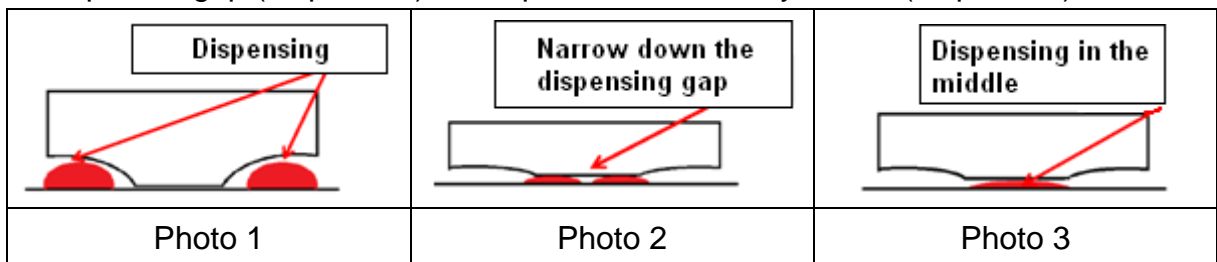

Remark

IT'S NOT UNDER CONTROL FOR PDF FILE  
PLS NOTE THE VERSION STATED..

Issue Dep. DATA Center.

Do not copy without permission

Series No. **60**

10.4 Product warranted solder area

10.4.14527

Closing the edge 0.5mm might be wetting area, but the area wouldn't influence reliability.

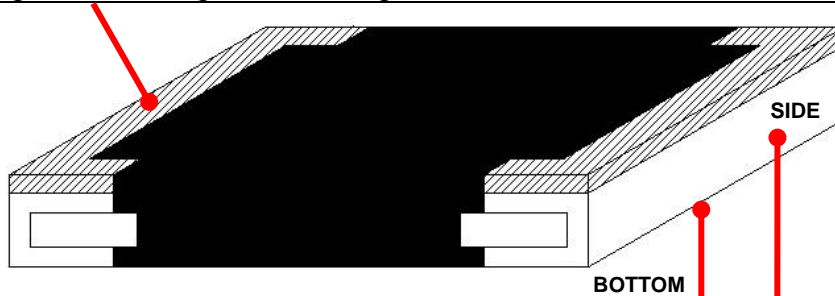

Solder coverage could be over 95%

10.4.2 Other Type

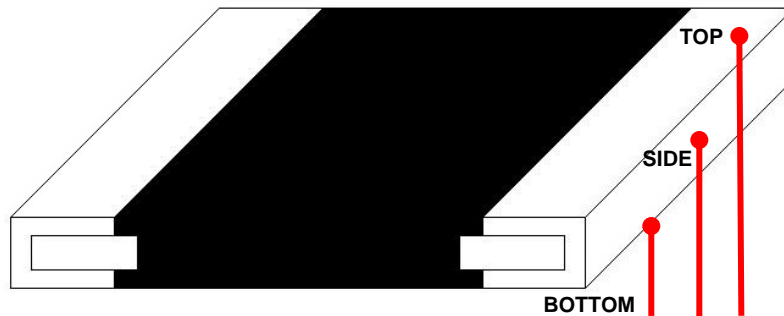

Solder coverage could be over 95%

10.5 The characteristic of Fe/Cr/Al alloy material:

Because of including magnetism, inductor will be generated under high frequency circuit then to cause value shift and influence customer application. If there is related application shall be noted especially or discuss with original factory.

10.6 Automobile Electronic Application:

This specification is for automobile electronic use. RALEC will take no responsibility if any damage, cost or loss occurs when the product has been used in any special circumstances.

Remark

IT'S NOT UNDER CONTROL FOR PDF FILE  
PLS NOTE THE VERSION STATED..

Do not copy without permission

Issue Dep. DATA Center.

Series No. **60**



**ACM-A Series Metal Alloy Low-Resistance Resistor Product Specifications (Automotive Grade)**

Document No.	IE-SP-080
Released Date	2019/10/25
Page No.	21

**10.7 Environment Precautions:**

If consumer intends to use our company product in special environment or condition (including but not limited to those mentioned below), then will need to make individual recognition of product features and reliability accordingly.

- (a) Used in high temperature and humidity environment
- (b) Exposed to sea breeze or other corrosive gas, such as Cl<sub>2</sub> · H<sub>2</sub>S · NH<sub>3</sub> · SO<sub>2</sub> and NO<sub>2</sub>.
- (c) Used in non-verified liquids including water, oil, chemical and organic solvents.
- (d) Using non-verified resin or other coating material to seal or coat our Company product.
- (e) After soldering, it is necessary to use water-soluble detergents to clean residual solder fluxes, even though no-clean fluxes are recommended.

**10.8 Momentary Overload Precautions:**

The product might be out of function when momentary overloaded. Please make sure to avoid momentary overloading while using and preserving.

**10.9 Operation and Processing Precautions:**

- (a) Avoid damage to the edge of resistor and protective layer caused by mechanical stress.
- (b) Handle with care when printing circuit board (PCB) is divided or fixed on support body, because bending of printing circuit board (PCB) mounting will make mechanical stress for resistors.
- (c) Make sure the power rating is under the limit when using the resistor. When power rating is over the limit, the resistor will be overloaded. There might be machinery damage due to the climbing temperature.
- (d) If the resistor will be exposed under massive impact load (shock wave) in a short period of time, the working environment must be set up well before use.
- (e) Please make evaluation and confirmation when the product is well used in your company and have a through consideration of its fail-safe design to ensure the system safety.

Remark	<div style="border: 1px solid black; padding: 5px; display: inline-block;">             IT'S NOT UNDER CONTROL FOR PDF FILE              PLS NOTE THE VERSION STATED..           </div>	Issue Dep. <b>DATA Center.</b>
	Do not copy without permission	



**ACM-A Series Metal Alloy Low-Resistance Resistor Product Specifications (Automotive Grade)**

Document No.	IE-SP-080
Released Date	2019/10/25
Page No.	22

**11 Storage and Transportation requirement:**

- 11.1 The temperature condition must be controlled at  $25\pm 5^{\circ}\text{C}$ , the R.H. must be controlled at  $60\pm 15\%$ . The stock can maintain quality level in two years.
- 11.2 Please avoid the mentioned harsh environment below when storing to ensure product performance and its' weldability. Places exposed to sea breeze or other corrosive gas, such as  $\text{Cl}_2$ 、 $\text{H}_2\text{S}$ 、 $\text{NH}_3$ 、 $\text{SO}_2$  and  $\text{NO}_2$ .
- 11.3 When the product is moved and stored, please ensure the correct orientation of the box. Do not drop or squeeze the box. Otherwise, the electrode or the body of the product may be damaged.

**12 Attachments**

- 12.1 Document Revise Record (QA-QR-027)

Remark	IT'S NOT UNDER CONTROL FOR PDF FILE PLS NOTE THE VERSION STATED..	Issue Dep. <b>DATA Center.</b>
	Do not copy without permission	Series No. <b>60</b>



**ACM-A Series Metal Alloy Low-Resistance Resistor Product Specifications (Automotive Grade)**

Document No.	IE-SP-080
Released Date	2019/10/25
Page No.	23

**Legal disclaimer**

RALEC, its distributors and agents (collectively, "RALEC"), hereby disclaims any and all liabilities for any errors, inaccuracies or incompleteness contained in any product related information, including but not limited to product specifications, datasheets, pictures and/or graphics. RALEC may make changes, modifications and/or improvements to product related information at any time and without notice.

RALEC makes no representation, warranty, and/or guarantee about the fitness of its products for any particular purpose or the continuing production of any of its products. To the maximum extent permitted by law, RALEC disclaims (i) any and all liability arising out of the application or use of any RALEC product, (ii) any and all liability, including without limitation liability for any loss of profits or for direct, indirect, special, punitive, consequential or incidental damages arising out of or related to RALEC products, and (iii) any and all implied warranties, including warranties of fitness for a particular purpose, non-infringement and merchantability.

RALEC defined this product is for automotive electronic use , not design for any application for medical life-saving or life support equipment, or any application which may inflict casualties if RALEC product failure occurred. Any and all technical advice furnished by RALEC with reference to the use of RALEC products are given free of charge and RALEC assumes no obligation or liability for the advice given or results obtained, and all such advice are given and accepted at buyer's risk. Buyer shall assume all risk and liability for the results obtained by the use of any RALEC products in combination with other articles or material or in the practice of any process, regardless of any oral or written technical statement made by RALEC with respect to the use of such products by way of technical advice or otherwise. Further, buyer represents and warrants that it has the experience and capacity of determining the correct product for its intended application.

Information provided here is intended to indicate product specifications only. RALEC reserves all the rights for revising this content without further notification, as long as products are unchanged. Any product change will be announced by ECN.

Remark	<div style="border: 1px solid black; padding: 5px; display: inline-block;">                 IT'S NOT UNDER CONTROL FOR PDF FILE                  PLS NOTE THE VERSION STATED..             </div>	Issue Dep. <b>DATA Center.</b>
	Do not copy without permission	Series No. <b>60</b>